

TOP VIEW

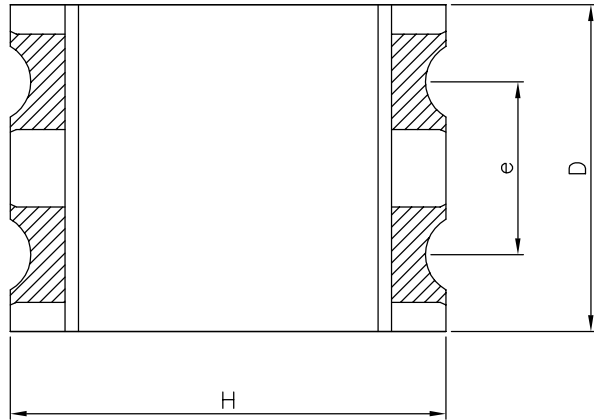

BOTTOM VIEW

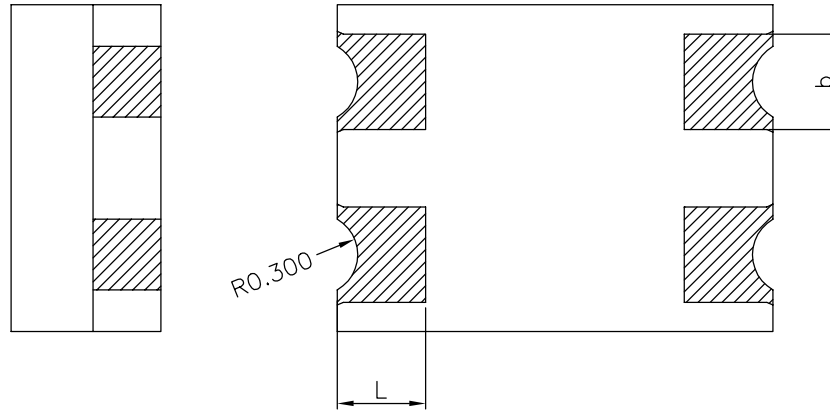

SIDE VIEW

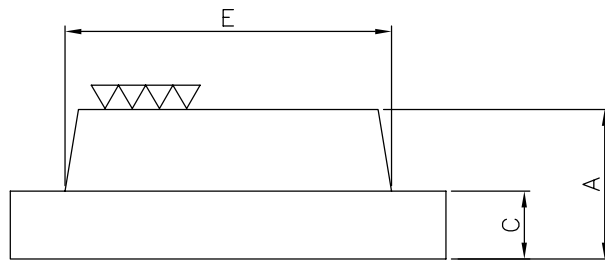

Note:
 1. Controlling dimension in millimeter.
 2. Die thickness after grinding: 10mils.



SYMBOLS	DIMENSIONS IN MILLIMETERS		
	MIN	NOM	MAX
A	1.00	1.10	1.20
b	0.60	0.70	0.80
C	—	0.50	—
D	2.30	2.40	2.50
E	2.30	2.40	2.50
e	—	1.27	—
H	3.10	3.20	3.30
L	0.55	0.65	0.75

CUSTOMER :		LINGSEN 5-1 NAN 2ND ROAD T.E.P.Z PRECISION IND., LTD TAICHUNG., TAIWAN R. O. C	
APPROVED BY	DATE	TITLE:	
DRAW BY: Kevin Liao	11/12/04	COB 4L(2.4x3.2mm) Package Outline Drawing	
CHECK BY: Eric Yen	11/12/04	DWG. NO.	PO-COB-012
APPROVAL: Jack Tu	11/12/04	REV.	2
APPROVAL: Jack Tu	11/12/04	UNIT :	mm
		SCALE :	20/1
		SHEET	1 OF 1