

DETAIL "A"

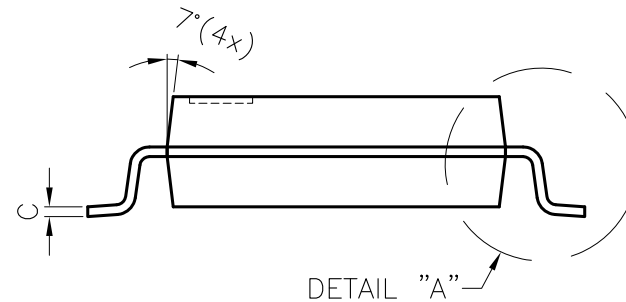
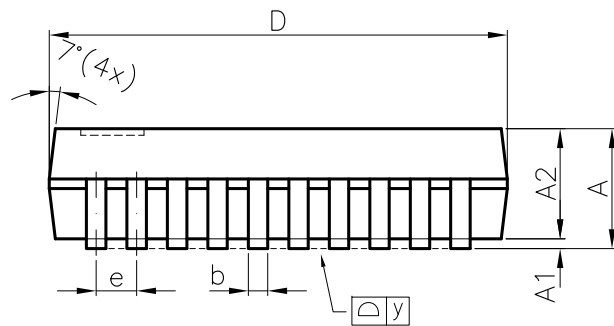

NOTE :

1. CONTROLLING DIMENSION : INCH
2. LEAD FRAME MATERIAL : COPPER 194
3. DIMENSION "D" DOES NOT INCLUDE MOLD FLASH, TIE BAR BURRS AND GATE BURRS. MOLD FLASH, TIE BAR BURRS AND GATE BURRS SHALL NOT EXCEED 0.006"[0.15mm] PER END DIMENSION "E1" DOES NOT INCLUDE INTERLEAD FLASH. INTERLEAD FLASH SHALL NOT EXCEED 0.010"[0.25mm] PER SIDE.
4. DIMENSION "b" DOES NOT INCLUDE DAMBAR PROTRUSION. ALLOWABLE DAMBAR PROTRUSION SHALL BE 0.003"[0.08mm] TOTAL IN EXCESS OF THE "b" DIMENSION AT MAXIMUM MATERIAL CONDITION. DAMBAR CANNOT BE LOCATED ON THE LOWER RADIUS OR THE FOOT. MINIMUM SPACE BETWEEN PROTRUSION AND AN ADJACENT LEAD TO BE 0.0028"[0.07mm]
5. TOLERANCE : ±0.010"[0.25mm] UNLESS OTHERWISE SPECIFIED.
6. OTHERWISE DIMENSION FOLLOW ACCEPTABLE SPEC.
7. REFERENCE DOCUMENT : JEDEC SPEC MO-150

SYMBOLS	DIMENSIONS IN MILLIMETERS			DIMENSIONS IN INCHES		
	MIN	NOM	MAX	MIN	NOM	MAX
A	—	—	2.00	—	—	0.079
A1	0.05	—	—	0.002	—	—
A2	—	1.75	—	—	0.069	—
b	0.22	0.30	0.38	0.0086	0.012	0.015
C	0.13	0.15	0.20	0.0051	0.006	0.0079
D	7.08	7.20	7.34	0.279	0.284	0.289
E	7.40	7.80	8.20	0.291	0.307	0.323
E1	5.00	5.30	5.60	0.197	0.209	0.220
e	—	0.65	—	—	0.0256	—
L	0.56	0.75	0.97	0.022	0.030	0.037
Ø	—	4'	8'	—	4'	8'
y	—	—	0.076	—	—	0.003

CUSTOMER :		<b>LINGSEN</b> 5-1 NAN 2ND ROAD T.E.P.Z PRECISION IND., LTD TAICHUNG, TAIWAN R. O. C	
APPROVED BY	DATE	TITLE:	
DRAW BY: <i>Monica Chen</i>	09/29/99	20L MEDIUM FINE PITCH STANDARD SMALL OUTLINE PACKAGE DRAWING	
CHECK BY: <i>Leo Chen</i>	12/01/99		
APPROVAL: <i>Paul Liu</i>	12/01/99	DWG. NO.	PO-SSOP-010
APPROVAL: <i>Jack Tu</i>	12/01/99	REV.	0
UNIT :	INCH	SCALE :	12/1
		SHEET	1 OF 1