

DETAIL A

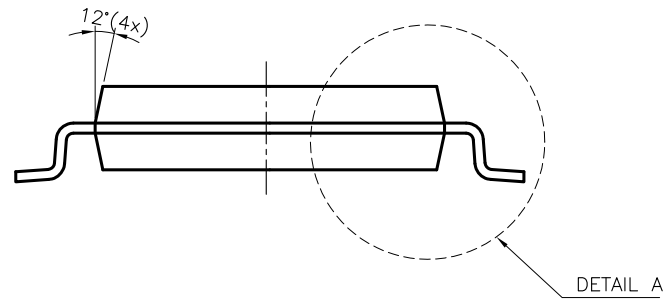
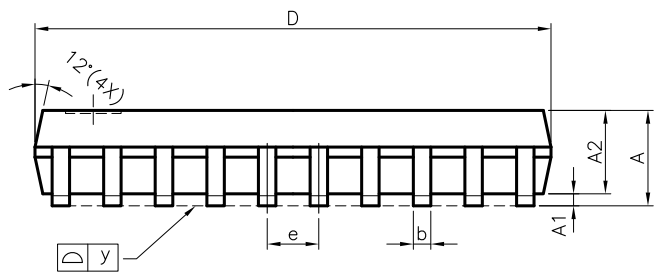

DETAIL A

NOTE :

1. CONTROLLING DIMENSION : mm
2. LEAD FRAME MATERIAL : OLIN C7025/EFTEC 64T
3. DIMENSION "D" DOES NOT INCLUDE MOLD FLASH, TIE BAR BURRS AND GATE BURRS. MOLD FLASH, TIE BAR BURRS AND GATE BURRS SHALL NOT EXCEED 0.006"[0.15mm] PER END DIMENSION "E1" DOES NOT INCLUDE INTERLEAD FLASH. INTERLEAD FLASH SHALL NOT EXCEED 0.010"[0.25mm] PER SIDE.
4. DIMENSION "b" DOES NOT INCLUDE DAMBAR PROTRUSION. ALLOWABLE DAMBAR PROTRUSION SHALL BE 0.003"[0.08mm] TOTAL IN EXCESS OF THE "b" DIMENSION AT MAXIMUM MATERIAL CONDITION. DAMBAR CANNOT BE LOCATED ON THE LOWER RADIUS OR THE FOOT. MINIMUM SPACE BETWEEN PROTRUSION AND AN ADJACENT LEAD TO BE 0.0028"[0.07mm]
5. TOLERANCE :  $\pm 0.010$ "[0.25mm] UNLESS OTHERWISE SPECIFIED.
6. OTHERWISE DIMENSION FOLLOW ACCEPTABLE SPEC.
7. REFERENCE DOCUMENT : JEDEC SPEC MO-153



SYMBOLS	DIMENSIONS IN MILLIMETERS			DIMENSIONS IN INCHES		
	MIN	NOM	MAX	MIN	NOM	MAX
A	—	—	1.20	—	—	0.047
A1	0.05	—	0.15	0.002	—	0.006
A2	0.80	1.00	1.05	0.031	0.039	0.041
b	0.19	—	0.30	0.007	—	0.012
C	0.09	—	0.20	0.0035	—	0.008
D	6.40	6.50	6.60	0.252	0.256	0.260
E	—	6.40	—	—	0.252	—
E1	4.30	4.40	4.50	0.170	0.173	0.177
e	—	0.65	—	—	0.026	—
L	0.45	0.60	0.75	0.0177	0.024	0.0295
L1	—	1.00	—	—	0.039	—
y	—	—	0.076	—	—	0.003
$\theta$	0°	—	8°	0°	—	8°

CUSTOMER :		<b>LINGSEN</b> 5-1 NAN 2ND ROAD T.E.P.Z PRECISION IND., LTD TAICHUNG, TAIWAN R. O. C	
APPROVED BY	DATE	TITLE:	
Rea Wang	09/11/02	20L TSSOP PACKAGE OUTLINE DRAWING (4.4mm)	
CHECK BY:			
Fan Win Lin	09/12/02		
APPROVAL:		DWG. NO.	REV.
Parker Chen	09/13/02	PO-TSSOP-008	2
APPROVAL:		UNIT :	SCALE :
Andy Yang	09/13/02	mm	15/1
		SHEET 1 OF 1	